

I-9103 Intelligent Rate of Rise and Fixed Temperature Heat Detector Installation and Operation Manual

(Issue 2.01, July 2005)

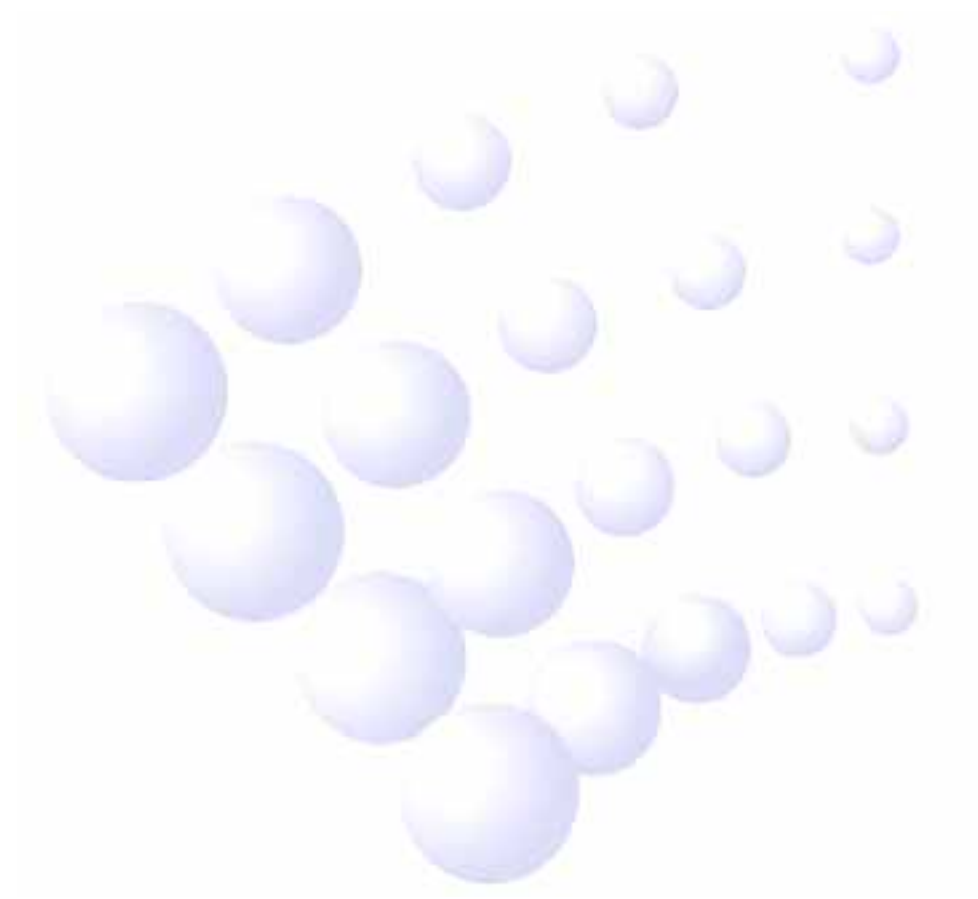

CONTENTS

I	General	1
II	Features	1
III	Technical Specifications	1
IV	Structure and Operation Principle	2
V	Mounting and Wiring	2
VI	Testing.....	3
VII	Operation.....	3
VIII	Troubleshooting.....	3
IX	Cautions.....	4

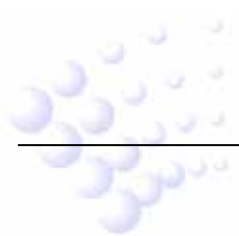

I General

I-9103 Intelligent Rate of Rise and Fixed Temperature Heat Detector (hereinafter called the detector) adopts non-polarized two-bus. It can be connected with the alarm bus of different kinds of GST fire alarm control panel in parallel in any mode. Adopting the microprocessor with A/D transformation, with novelty structure, attractive appearance, stable and reliable performance, the detector is especially applicable to places where fire occurs with highly rise temperature. Used together with smoke detectors, it can detect fire with more reliability to reduce losses.

II Features

1. Connecting with the control panel by non-polarized two-bus.
2. The address code is written in directly by electronic programmer, making engineering simple and reliable.
3. Remote output terminal connecting with remote LED.
4. Microprocessor can collect and process data in real time and can store 14 history data, displaying and tracking field condition by curves.

III Technical Specifications

1. Operating Voltage: Loop 24V (16V ~ 28V)
2. Operating Current:
 - Standby Current 0.8mA
 - Alarm Current 2.0mA
3. Alarm Confirming LED: Red (flashes in polling, constantly lights when alarming)
4. Programming Mode: Decimal electronic programming within 1 ~ 242.
5. Detection Angle 45°
6. Remote output: Directly connecting with remote LED (5.1k resistor in series is inside, output voltage is 4.3V).
7. Monitoring Area: When space height is less than 8m, the monitoring area of a detector is 20m² ~ 30m² for normal protection area.
8. Operating Environment:
 - Temperature: -10 ~ +50
 - Relative Humidity 95%, non condensing
9. Dimension:
 - Diameter: 100mm
 - Height: 45mm (excluding the base)
10. Ingress Protection Rating: IP53
11. Material and Color of Enclosure: ABS, ivory white
12. Weight: About 115g
13. Mounting Hole Distance: 45mm ~ 75mm
14. According to Standard: EN 54-5

IV Structure and Operation Principle

1. Appearance of the detector is shown in Fig. 1.

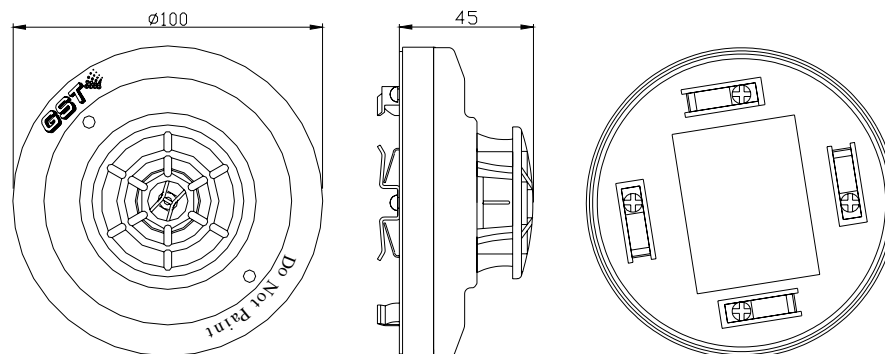

Fig.1

2. Operation Principle:

The detector uses a thermistor as its sensor, whose output signal is input into its microprocessor after voltage transformation, and the microprocessor processes the signal by intelligent arithmetic. When the microprocessor checks fire signal, it sends the signal to the control panel and lights the fire LED through the control panel.

V Mounting and Wiring

1. Mounting of the detector is shown in Fig. 2.

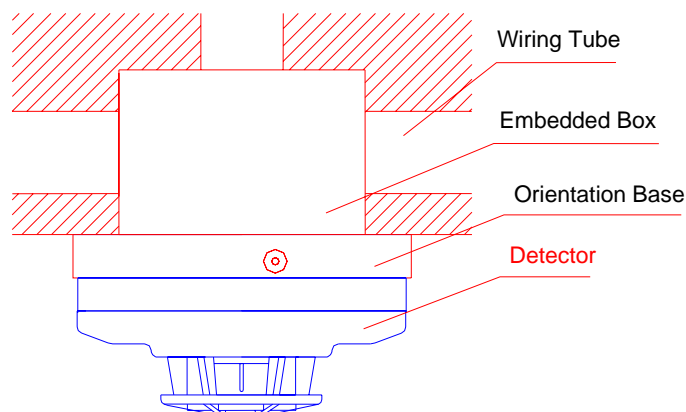

Fig. 2

2. The base of the detector is shown in Fig. 3 and orientation base in Fig. 4. There are four conducting pieces on the orientation base, each carrying a terminal with number. The detector bus in the wiring tube can be connected with any two diagonal conducting pieces "1" and "3" (non-polarized). "2" is for anode of the remote LED and "4" is for the cathode. These are used to fix the detector accessarily: There are location elements on the bottom of the detector (mark C) and on the orientation base (mark A and B). When installing, align mark C to mark A and rotate the detector clockwise to mark B. The detector is installed.

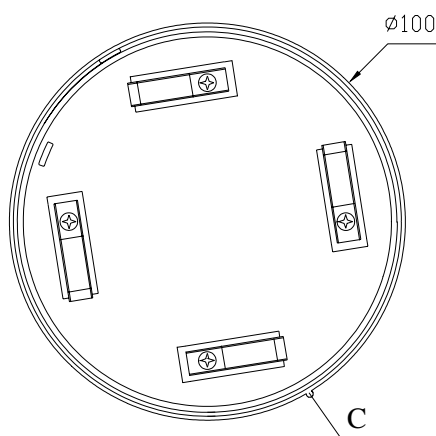

Fig. 3

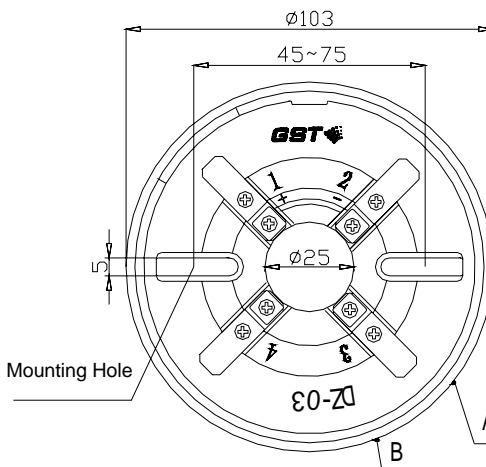

Fig. 4

3. Wiring: Twisted pair for detector's two-bus with cross section not less than 1.0mm^2 laid out through metal tube or flame-resistant tube. The cables should be different colors to distinguish polarity.

VI Testing

Warning: Power up only after all the detectors have been installed.

1. The detector must be tested by simulation fire half a year in order to check the detector works normally.
2. After testing, reset the detector through fire alarm control panel. Notify the proper authorities the system is back in operation. If the detector fails in the test, please return it for repair.

VII Operation

Programming/Reading address code.

Inputting code number within 1 ~ 242, pressing *Program*, the screen will display a "P" meaning the corresponding address is written in. Press *Clear* to return. If the programming is a failure, "E" will be displayed. Pressing *Clear* to display "0", you can repeat the operation. Pressing *Read*, the screen will display address code. If it fails, the "E" will be displayed. Pressing *Clear* to display "0", you can repeat the operation.

VIII Troubleshooting

1. Alarming fault:

Read code of the detector reporting fault by the programmer, if the code is correct in two kinds of bus polarity, the detector is operating normally; then check the wiring to the detector base, if the code cannot be read correctly in any kind of polarity, return the detector for repair.

2. Nuisance alarm:

Check whether the thermistor is shorted by crossing of base pins.

IX Cautions

1. The detector should be installed just before commission and kept well before installation, taken corresponding measures for dust-proof, damp-proof and corrosion-proof. The dust cover cannot be removed until the project has been plunged into usage.
2. There should not be any obstruction within 0.5m around the detector.
3. The horizontal distance from the detector to the blast hole of any air-conditioner should not be less than 1.5m.
4. The horizontal distance from the detector to the wall or the girder should not be less than 0.5m.
5. The detector should be installed horizontally. If it has to be installed aslant, the gradient angle should not be more than 45°.
6. The detector base should be installed securely and the leads connected reliably.
7. The alarm confirming LED should face the main entrance where it's convenient for personnel to observe.
8. In maintenance, be careful to avoid damage to the detector.
9. When installing detectors on corridor ceilings not wider than 3m, they should be placed in the middle. The spacing should not be more than 10m.
10. The detector is not suitable for places where smoldering fire is possible to occur.

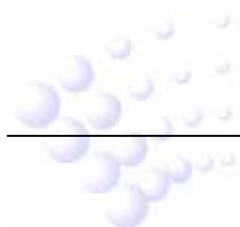



GST China

Gulf Security Technology Co., Ltd.

No. 80, Changjiang East Road, QETDZ, Qinhuangdao, Hebei,
P. R. China 066004

Tel: +86 (0) 335 8502528

Fax: +86 (0) 335 8508942

Email: sales@gst.com.cn

www.gst.com.cn

GST UK

Global System Technology PLC

Staunton Harold Hall, Staunton Harold Ashby-de-la Zouch, Leicestershire,
England LE65 1RT

Tel : +44 (0)1530 564764

Fax : +44(0)1530 564769

Rigional Office

PO Box 17998 Unit ZA04 JEBEL ALI Free Zone,
Dubai, UAE

Tel: +971 (0) 4 8833050

Fax: +971 (0) 4 8833053

Email: tech.support@gst.uk.com

www.gst.uk.com