

**I-9404 Intelligent Sounder**  
**I-9403 Intelligent Sounder Strobe**  
**Installation and Operation Manual**

**(Issue 2.02, December 2005)**

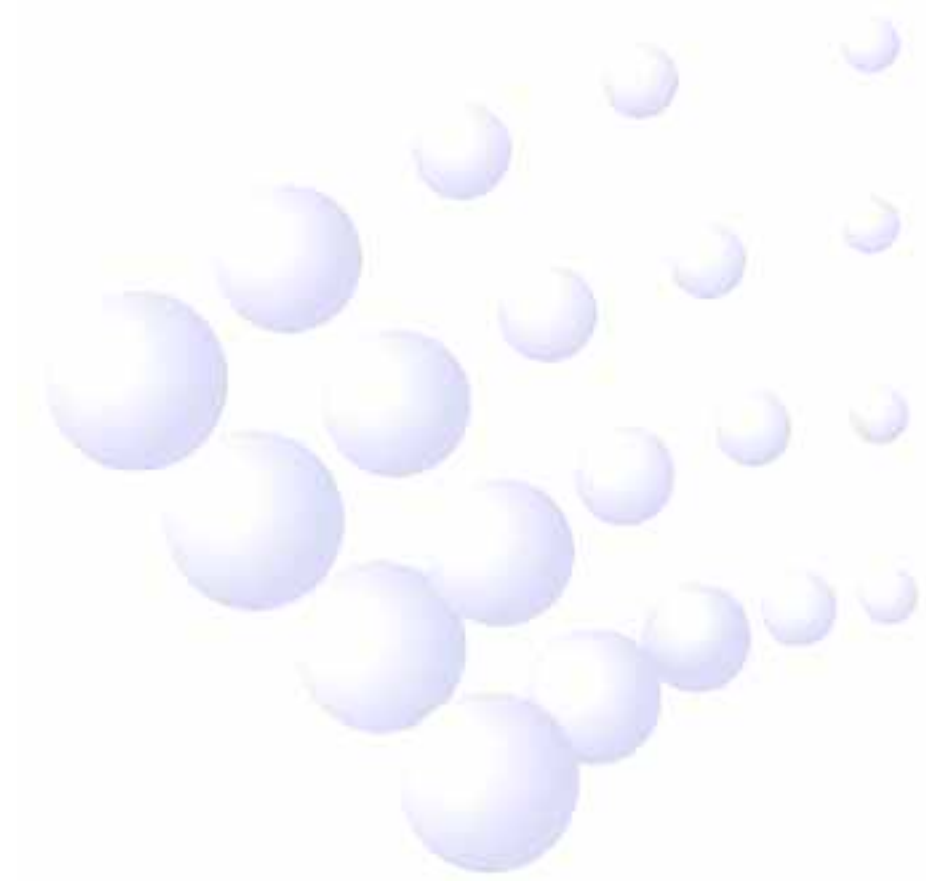

## CONTENTS

I	General .....	1
II	Features .....	1
III	Technical Specifications .....	1
IV	Structure and Operation Principle .....	2
V	Mounting and Wiring .....	3
VI	Testing .....	4
VII	Operation .....	4
VIII	Applications .....	5
	Appendix: Sound Level Data .....	6

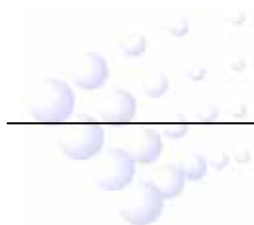

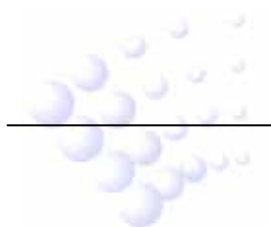

## I General

I-9404 Intelligent Sounder and I-9403 Intelligent Sounder Strobe (hereinafter called the sounder/sounder strobe) is a kind of audible/audible and visual alarm device installed in field, which can be activated by fire alarm control panel in fire control center or by manual call point installed in field. After activated, it will generate strong audible/audible and visual alarm signal to warn people in field.

## II Features

1. Having two alarm modes (Mode I and Mode II) to distinguish pre-alarm and fire alarm.
2. Several strong red LEDs as light source, which are striking, long-life and low consumption.
3. Activating the sounder strobe by shorting external terminals is not affected by the power cut of signal bus.
4. Signal bus and power bus are non-polarized, which is convenient for wiring and has the function of checking power-off. In case of power-off, it can transmit the fault signal to the control panel.

## III Technical Specifications

1. Wiring: Four wires, connecting with the control panel by non-polarized signal two-bus, and connecting with power cable by non-polarized two-wire.
2. Operating Voltage:  
Signal Bus Voltage: 24V (16V ~ 28V)  
Power Bus Voltage: 24VDC (20VDC ~ 28VDC)
3. Operating Current:  
Loop Standby Current 1mA Loop Activating Current 5mA  
Power Standby Current 3mA Power Action Current 50mA
4. Main Sound Frequency: 2.8kHz
5. Mode I (for pre-alarm):  
Sound Level: 75dB~85dB (at 3m ahead horizontally (A weighted))  
Flashing Frequency:  $0.7 \times (1 \pm 20\%)$ Hz  
Sound Pattern: 0.61Hz (430ms on /1200ms off)
6. Mode II (for fire alarm):  
Sound Level: 85dB~115dB (at 3m ahead horizontally (A weighted))  
Flashing Frequency:  $1.4 \times (1 \pm 20\%)$ Hz  
Sound Pattern: 1.30Hz (430ms on /340ms off)
7. Programming Mode: Electronic programming within 1 ~ 242, occupying 1 or 2 (when device type is 121) loop address point.

8. Operating Environment:  
Temperature: -10 ~ +50  
Relative Humidity 95%, non condensing
9. Dimension: 110mm × 97.5mm 110mm × 83mm ( thin base )
10. Weight:  
I-9404: About 345g I-9404: About 317.2g (thin base)  
I-9403: About 355g I-9403: About 327.2g (thin base)
11. Material and Color of Enclosure: ABS/Red, front is plexiglass/red.
12. Mounting Hole Spacing: 55mm ~ 80mm

## IV Structure and Operation Principle

1. The sounder/sounder strobe can connect with thick base of 40mm or thin base of 25.5mm. Their appearances are shown in Fig. 1a and Fig. 1b.

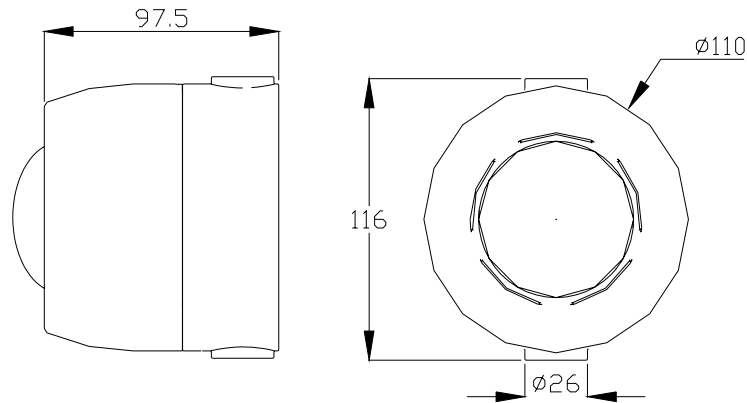

Fig. 1 a

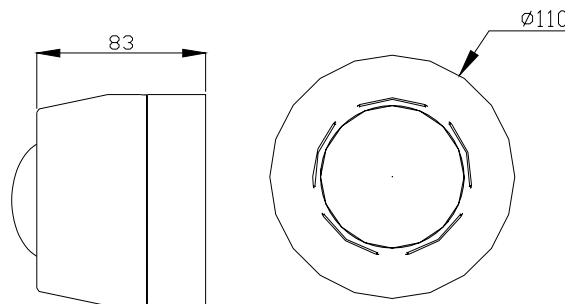

Fig. 1b (thin base)

### 2. Operation Principle

Built-in processor realizes communication with control panel, checking of power-off and activation of audible and visual signal. When it's activated by external contacts, timing oscillation circuit controls the on-off of the buzzer circuit to generate alarm sound, controlling 6 highlighted LEDs to generate flashing light signal. When receiving activation command from the control panel, the sounder strobe will initiate audible and visual signal and can change the on-off of alarm sound and flashing frequency by controlling the data in timing oscillation circuit.

## V Mounting and Wiring

**Warning: Before installing, disconnect the power from the loop.**

1. Before installation, check the enclosure and labels.
2. The sounder/sounder strobe is surface mounted. For normal space height, it should be placed 0.2m from the ceiling. When wiring tube is embedded, it can be mounted on embedded box; when wiring tube is surface mounted, knock the knock-off hole, then connect the wiring tube with it. The mounting hole distance and mounting direction are shown in Fig. 5. Mounting method is shown in Fig. 2 and Fig. 3.
3. When the thin base is required, the sounder/sounder strobe only adopts wiring tube embedded. Its mounting method is shown in Fig. 2b.

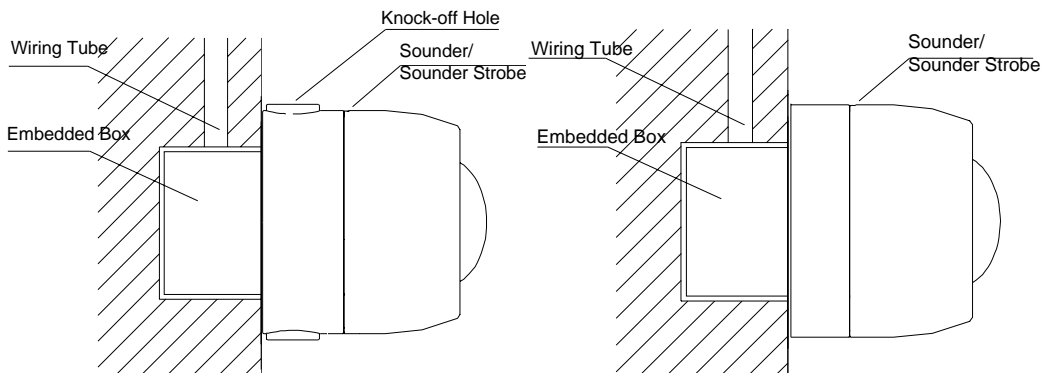

Fig. 2a

Fig. 2b

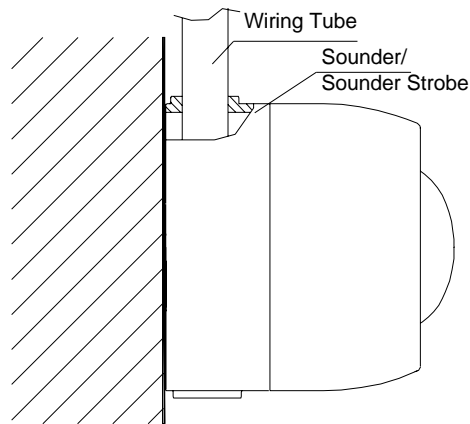

Fig. 3

3. The base and the sounder/sounder strobe are twisted together. When mounting, remove the sounder/sounder strobe, thread cables through the wire-in hole on the base and connect with corresponding terminals, then twist the sounder/sounder strobe onto the base.
4. If the sounder/sounder strobe is required anti-removal, knock down the arch knock-off hole as shown in Fig. 4 and fix it with ST2.9 x 6.5 tapping screws (in this case, it must be removed by special tools).

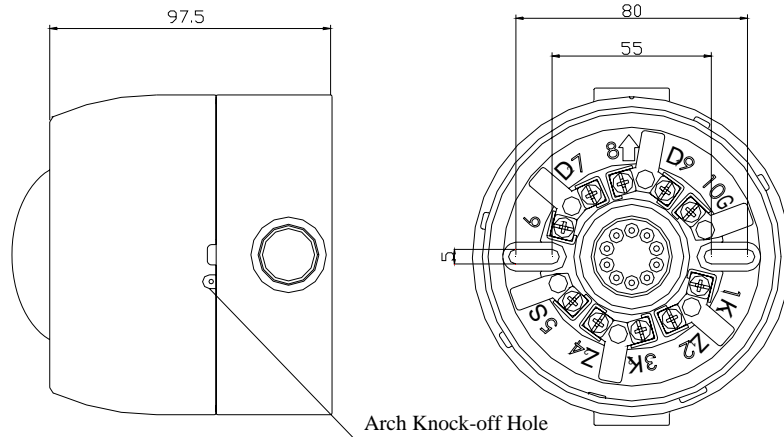

Fig. 4

Fig. 5

5. Terminals on the base are shown in Fig. 5.  
Z1 (2), Z2 (4): Control panel signal bus, non-polarized.  
D1 (9), D2 (7): To 24VDC power, non-polarized.  
S (5), G (10): External passive input.
6. Wiring: Twisted pair for signal bus Z1 and Z2, cross section not less than 1.0mm<sup>2</sup>;  
227 IEC 01 cable for power wire D1, D2 and external wire S, G, cross section not less than 1.5mm<sup>2</sup>.

## VI Testing

**Warning: Power up only after all devices are well connected.**

1. Test should be made to the sounder/sounder strobe after installation and at least once a year after put into operation.
2. Before testing, notify the proper authorities that the system is undergoing maintenance and will temporarily be out of service. Disable the zone or system undergoing maintenance to avoid unwanted alarms.
3. Testing: Activate the sounder/sounder strobe by external contacts and control panel respectively, it should be activated and generate audible/audible and visual alarm signal.
4. After testing, reset the sounder/sounder strobe. Notify the proper authorities the system is back in operation.
5. If a sounder/sounder strobe fails in testing, check its connection and test again. If it still fails, please return it for repair.

## VII Operation

1. When device type of the sounder/sounder strobe is 121, it occupies two consecutive addresses; when device type is other numbers (factory default is 27), it occupies one address.
2. Two activating methods when the sounder/sounder strobe is in Mode I:

- a) Short external controlled input terminals S and G to activate the sounder/sounder strobe.
  - b) When the sounder/sounder strobe occupies two addresses, activate the first through the control panel.
3. Two activating methods when the sounder/sounder strobe is in Mode II:
- a) When the sounder/sounder strobe occupies one address, activate it through the control panel.
  - b) When the sounder/sounder strobe occupies two addresses, activate the second through the control panel.

## VIII Applications

The wiring method of signal bus and power bus of the sounder/sounder strobe and the method of direct control through passive normally open contact K1 and K2 of the manual call point are shown in Fig. 6.

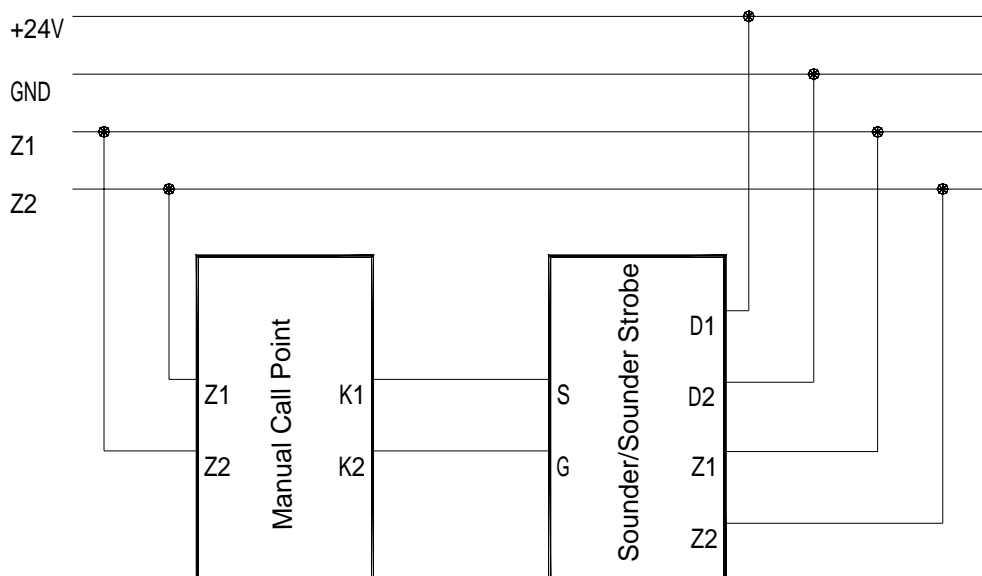
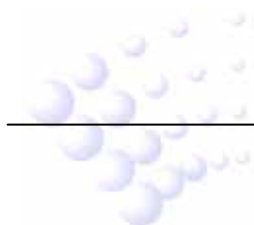

Fig. 6



## Appendix: Sound Level Data

### 1 Tone a (alarm), Maximum Volume

Angle	Horizontal		Vertical	
	20	28V	20	28V
15°	75.19	77.17	72.85	72.31
45°	84.01	87.07	82.57	85.63
75°	87.61	90.85	86.98	89.32
105°	87.43	90.22	88.42	90.67
135°	83.11	86.17	83.65	86.80
165°	70.60	73.84	75.55	77.98

### 2 Tone b (pre-alarm), Maximum Volume

Angle	Horizontal		Vertical	
	20	28V	20	28V
15°	72.67	75.73	61.15	65.11
45°	80.50	83.20	78.61	81.40
75°	84.37	87.25	83.56	86.53
105°	83.65	86.53	84.91	88.15
135°	79.51	82.57	80.32	83.65
165°	66.10	69.61	70.78	74.11

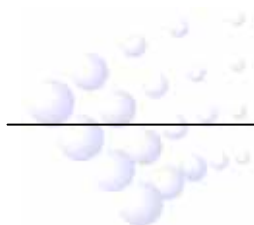

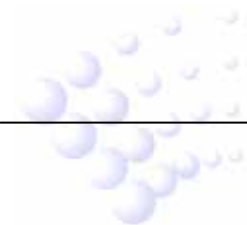



## **GST China**

### **Gulf Security Technology Co., Ltd.**

No. 80, Changjiang East Road, QETDZ, Qinhuangdao, Hebei,

P. R. China 066004

Tel: +86 (0) 335 8502528

Fax: +86 (0) 335 8508942

Email: [sales@gst.com.cn](mailto:sales@gst.com.cn)

[www.gst.com.cn](http://www.gst.com.cn)

## **GST UK**

**Global System Technology PLC**

Enterprise Glade, Bath Lane, Moira, South Derbyshire,  
England. DE12 6BD

Tel: + 44 (0) 1283 225 478

Fax: + 44 (0) 1283 220 690

**Regional Office**

PO Box 17998 Unit ZA04 JEBEL ALI Free Zone,  
Dubai, UAE

Tel: +971 (0) 4 8833050

Fax: +971 (0) 4 8833053

Email: [tech.support@gst.uk.com](mailto:tech.support@gst.uk.com)

[www.gst.uk.com](http://www.gst.uk.com)