

**C-9103 Conventional Rate of Rise and
Fixed Temperature Heat Detector
Installation and Operation Manual**
(Issue 1.11, March 2006)

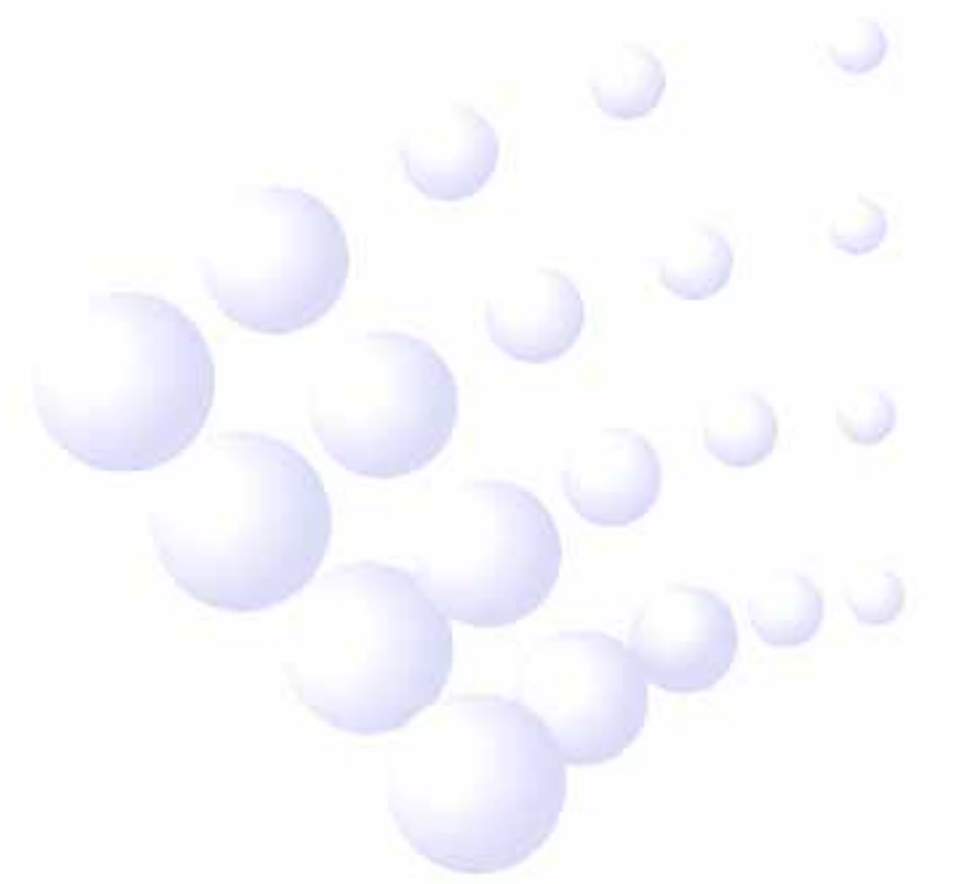

CONTENTS

I	General.....	1
II	Features	1
III	Technical Specifications.....	1
IV	Structure and Operation Principle.....	2
V	Mounting and Wiring.....	2
VI	Applications	3
VII	Troubleshooting	4
VIII	Cautions	4

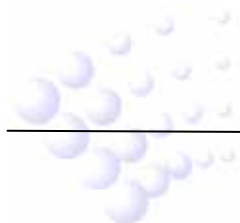

I General

C-9103 Conventional Rate of Rise and Fixed Temperature Heat Detector (hereinafter called the detector) checks ambient temperature with the sensitive feature of the thermo-sensitive elements. With a built-in SCM, it's fixed with highly reliable fire judging program. Special processing technology ensures its stable and reliable operation. Matching with P-9907 Active End of Line Unit, it can connect with compatible fire alarm controller to process detector signals.

II Features

With novelty structure, attractive appearance, stable and reliable performance, the detector is especially applicable to places where fire occurs with a sharp rise of temperature. Used together with smoke detectors, it can detect fire with more reliability to reduce losses. The detector has a remote LED output terminal to connect with remote LED.

III Technical Specifications

1. Operating Voltage: 12VDC ~ 28VDC
2. Static Current 60 μ A (Note: The detector can work within 12VDC ~ 28VDC in static state)
3. Alarming Current: 10mA I 30mA (Note: The alarming current depends on the current limit of the controller. It's not allowed to power the detector directly by 24VDC Otherwise it will be blown as a result of without current limiting resistor.)
4. Maximum Ripple Voltage: 4V(peak-to-peak value)
5. Alarm Reset: Instantaneous Cut out (5s MAX, 2.5VDC MAX)
6. Power-up Time 10s
7. Weight: About 120g
8. Monitoring Area: 30m² for space height not higher than 8m.
9. Operating Environment:
 - Temperature: -10 ~ +50
 - Relative Humidity 95%, no condensation
10. Dimension:
 - Diameter: 100mm
 - Height: 45mm (without base)
11. Wiring: Connecting with the power cable by polarized two-wire.
12. Alarm Confirming LED: Red, not lit when polling, constantly lit when alarming.
13. Remote LED Output: Directly connect with remote LED (with a 2k resistor connected in series inside).
14. Degree of Protection of Enclosure: IP53
15. Material and Color of Enclosure: ABS, ivory white
16. Mounting Hole Distance: 45mm ~ 75mm

IV Structure and Operation Principle

1. Appearance of the detector is shown in Fig. 1.

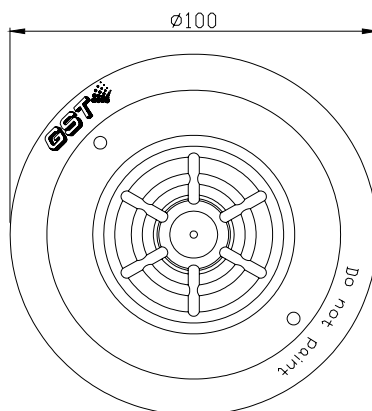

Fig. 1 Appearance

2. Operation Principle

The detector uses a thermistor as its sensor, whose output signal is input into its SCM after transformed by amplifying circuit, and the SCM processes the signal with algorithm. The detector adopts current output mode. When the SCM checks fire signal, it will light the fire LED, and the loop current increases.

V Mounting and Wiring

1. Mounting of the detector is shown in Fig. 2.

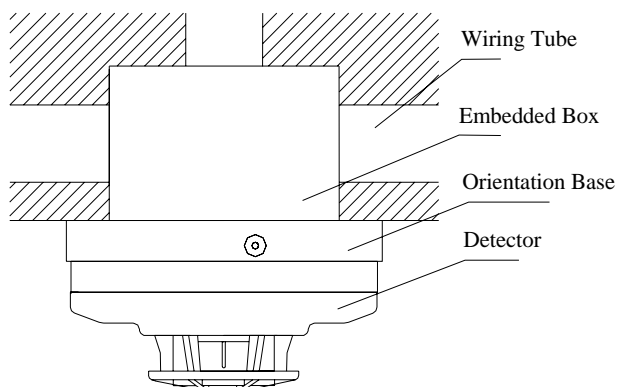

Fig. 2 Mounting

2. The bottom and orientation base of the detector are shown in Fig.3 and 4. There are four terminals with numbers on the base, "1" connects with the anode of the output end of compatible controller, "2" connects with the power anode of the next detector as output (terminal No. "1"), "3" connects with the power cathode of the next detector (terminal No. "3") and the cathode of the output end of compatible controller. "1" connects with anode of remote LED, "4" connects with cathode of remote LED. There are location elements on the detector and the orientation base to ensure there is only one installing position. There are two marks on point A and

B of the orientation base, and a mark on point C of the side face of bottom of the detector. When installing, aligning the mark C of the detector to point A of the orientation base, rotate the detector clockwise to point B, then the detector is installed.

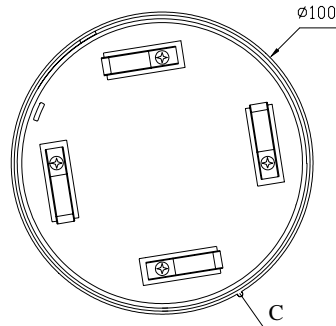

Fig.3 Bottom of the detector

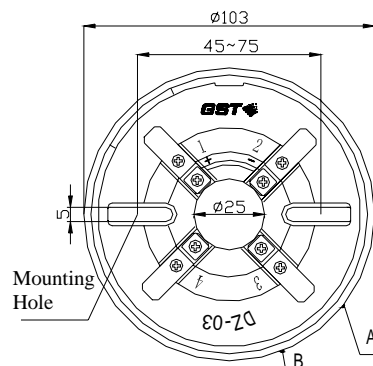

Fig. 4 Orientation base

3. Wiring: Twisted pair with cross section 1.0mm².

VI Applications

1. When the detector is connected with compatible controller in series, if a P-9907 Active End of Line Unit is connected to the loop output terminal, a diode IN5819 should be connected with the detector base.
- 1) When the active end of line unit is used as the detector base, that is to install a conventional detector on it, the system composition is shown in Fig.5.

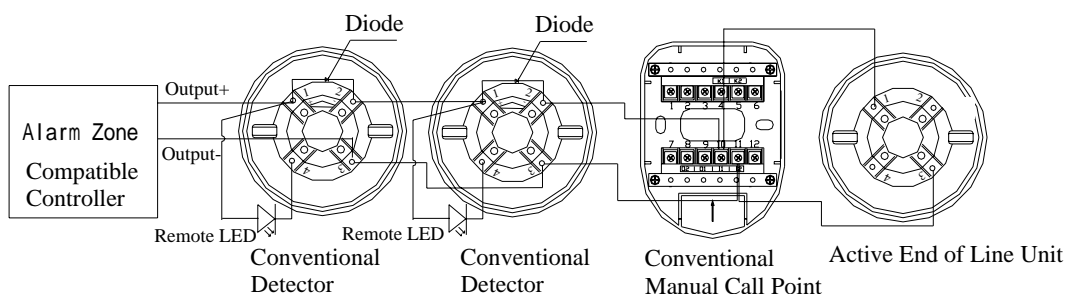

Fig. 5 System composition

- 2) When the active end of line unit is not used as the detector base, a cover should be added to it. The system composition is shown in Fig. 6.

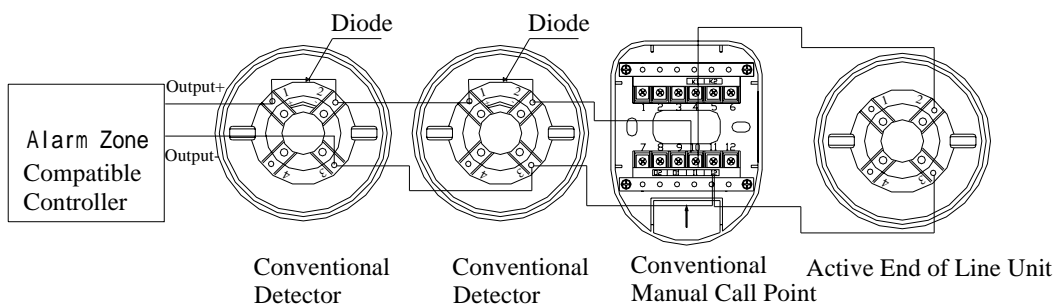

Fig. 6 System composition

- When the detector is connected with compatible controller in series, if a terminal resistor is connected to the loop output terminal, then no diode is connected to the detector base. The system composition is shown in Fig.7.

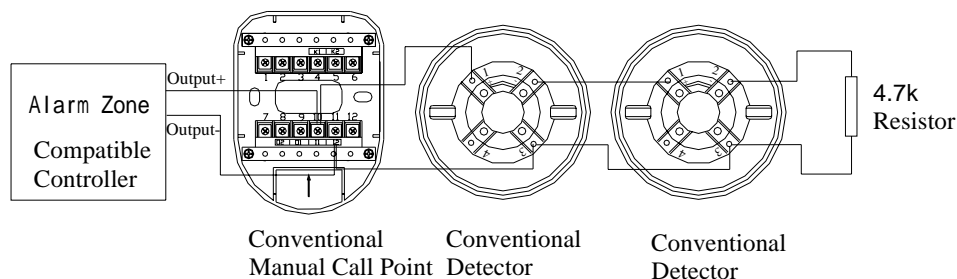

Fig. 7 System composition

Output loop of compatible controller can at most be connected with 15 conventional field devices. The compatible controller has the function of checking loop breakage. When any field device in the output loop is removed, it alarms fault. If P-9907 Active End of Line Unit is connected, it will not affect the normal operation of other field devices.

VII Troubleshooting

When any problem occurs, first check wiring correct or not and screws loose or not, then open the enclosure to see whether anywhere is not well soldered or is blown. Possible problems and solutions in commissioning are listed below.

- No alarm Check diode VD1, thermistor RT1, voltage stabilizing integrated circuit N1 and D1 and ambient circuits.
- Nuisance alarm Check triode VT2 and D1 etc.

VIII Cautions

Before installation, the detector should be kept well and taken corresponding measures for dust-proof, damp-proof and corrosion-proof. The dust cover cannot be removed until the project has been plunged into usage.



GST China

Gulf Security Technology Co., Ltd.

No. 80, Changjiang East Road, QETDZ, Qinhuangdao, Hebei,
P. R. China 066004

Tel: +86 (0) 335 8502528

Fax: +86 (0) 335 8508942

Email: sales@gst.com.cn

www.gst.com.cn

GST UK

Global System Technology PLC

Enterprise Glade, Bath Lane, Moira, South Derbyshire,
England. DE12 6BD

Tel: +44(0)1283225478

Fax: + 44 (0) 1283 220 690

Rigional Office

PO Box 17998 Unit ZA04 JEBEL ALI Free Zone,
Dubai, UAE

Tel: +971 (0) 4 8833050

Fax: +971 (0) 4 8833053

Email: tech.support@gst.uk.com

www.gst.uk.com