

Features

- Siren type of alarm sound
- High intensity LED flashing light
- Low profile design

Description

I-9401 is addressable electronic fire alarm sounder that is compatible to all GST addressable fire alarm control panel. I-9401 has siren type of sound and high intensity LED flashing light.

I-9401 is activated by the control panel. It remains activate until it receives the reset signals from the control panel.

I-9401 is wired in the addressable loop and requires 24 VDC power supply.

I-9401 will communicate continuously when in standby mode. By this mean the control panel will be noticed if the I-9401 fails or is lost. I-9401 will send the signal of fault to control panel if its power supply is lost.

I-9401 can be controlled by a voltage free normally open contact directly, for example, by GST manual call point I-9202.

Wiring

Terminals D1 and D2 are connected to DC24V power supply, non-polarized;

Terminals Z1 and Z2 are connected to loop of the controller, non-polarized;

Terminals S1 and G are connected to external contact only if it is used.

The loop cable shall be 2-core twist pair fire alarm cable with minimum size 1mm² (18AWG).

The power supply cable shall be single solid core with minimum size 1mm² (18AWG).



Specification

- Alarm sound level: 85 dB at 3m
- Flashing frequency: 20 to 180 times per minute
- Loop voltage: 16 V~28 V
- Standby loop current: 0.8mA
- Alarm loop current: 6.0mA
- Power supply voltage: 20VDC~28VDC
- Standby power current: 10mA
- Alarm power current: 160mA
- Address range: 1 to 242
- Operating temperature: -10°C~+50°C
- Humidity: <95%
- Dimension: 144 x 90 x 57 mm
- Weight: 255g
- Material and color: ABS, white
- Mounting: two holes with distance 65~80mm

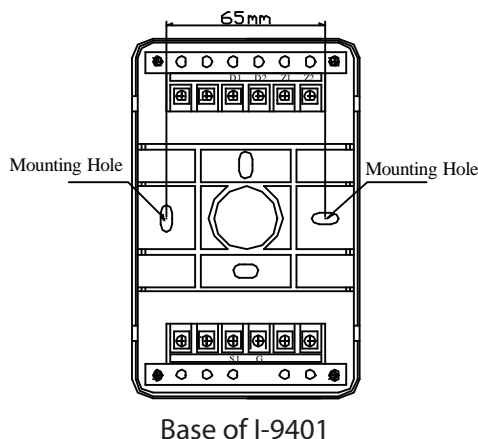

Base of I-9401

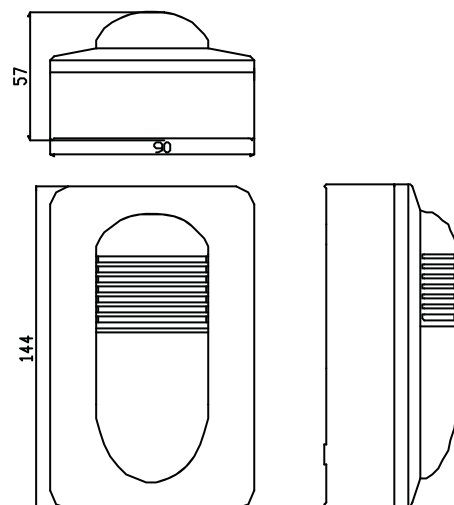

Installation

I-9401 consists of two parts: base and body. The base may be mounted on a electrical box with 2 screws or on flush surface. All wires shall be connected to the terminal of the base first. The body of I-9401 can be plugged onto the base.

Exclusive distributor

MASTER CONTROLS CO., LTD.

100/69 Vongvanit Complex Building B, 22nd Floor, Rama 9 Road, Huaykhwang, Bangkok 10320

Tel: 02645-1440-43 Fax: 02248-7701 www.mastercontrols.co.th

